

MINUTEMAN[®] **Power Technologies** *From Para Systems, Inc.*



EDBP1000T
Battery Pack

User's Manual

Para Systems, Inc.
1455 Lemay Dr.
Carrollton, TX 75007
Phone: 1-972-446-7363
Fax: 1-972-446-9011
Internet: minutemanups.com
UPS Sizing: sizemyups.com

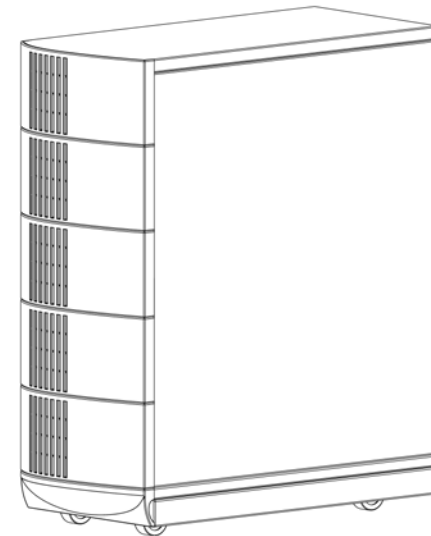

TABLE OF CONTENTS

1.	Introduction	2
2.	Controls	6
3.	Installation	7
4.	Replacing the Battery	11
5.	Obtaining Service	15
6.	Specifications	16
7.	Limited Product Warranty	17

1. INTRODUCTION

Thank you for purchasing this power protection product. It has been designed and manufactured to provide many years of trouble free service.

**IMPORTANT SAFETY INSTRUCTIONS
SAVE THESE INSTRUCTIONS !**

Please read this manual before installing your Endeavor Series Battery Pack, model EDBP10000T as it provides important information that should be followed during installation and maintenance of the Battery Packs and batteries allowing you to correctly set up your system for the maximum safety and performance. Included is information on customer support and factory service if it is required. If you experience a problem with the Battery Packs please refer to the Troubleshooting guide in this manual to correct the problem or collect enough information so that the Technical Support Department can rapidly assist you.



This symbol indicates "ATTENTION"



This symbol indicates "Risk of Electrical Shock"



This symbol indicates "Direct Current Supply"



This symbol indicates "Equipment Grounding Conductor"



CAUTION! To reduce the risk of electrical shock with the installation of these Battery Packs, with the UPS equipment and the connected equipment, the user must ensure that the combined sum of the AC leakage current does not exceed 3.5mA.



CAUTION! These Battery Packs are intended to be install in a temperature controlled environment that is free of conductive contaminants. Select a location which will provide good air circulation for the Battery Pack and UPS at all times.



WARNING: These Battery Packs contains potentially hazardous voltages. Do not attempt to disassemble the Battery Pack beyond the battery replacement procedure. These Battery Packs contains no user serviceable parts. Repairs and Battery replacement must be performed by **QUALIFIED SERVICE PERSONNEL ONLY**.



WARNING: Risk of Electrical Shock. Hazardous live parts inside these Battery Packs are energized from the battery.



CAUTION! To de-energize the Battery Pack:

1. If the UPS is on press the Off button on the front panel of the UPS.
2. Turn Off the input circuit breaker on the rear panel of the UPS.
3. Turn off the DC breaker on the rear panel of the Battery Pack.
4. Disconnect the battery cable from the rear panel of the UPS.
5. To de-energize the Battery Pack completely, disconnect the batteries.

Receiving Inspection

After removing your Battery Pack from its carton, it should be inspected for damage that may have occurred in shipping. Immediately notify the carrier and place of purchase if any damage is found. Warranty claims for damage caused by the carrier will not be honored. The packing materials that your Battery Pack was shipped in are carefully designed to minimize any shipping damage. In the unlikely case that the Battery Pack needs to be returned to the manufacturer, please use the original packing material. Since the manufacturer is not responsible for shipping damage incurred when the system is returned, the original packing material is inexpensive insurance.

PLEASE SAVE THE PACKING MATERIALS!

Unpacking Instructions

1. Cut the banding straps and discard them.
2. Lift the cardboard carton upwards off the packaging crate.
3. Cut the banding strap. Remove the ramp and the corner post. Remove the side blocks. Use a screwdriver to remove the end stop.
4. Place the ramp against the pallet. Remove the metal bracket and insert as shown to secure the ramp to the pallet.
5. Push the unit slowly down the ramp.

Unpacking Instructions

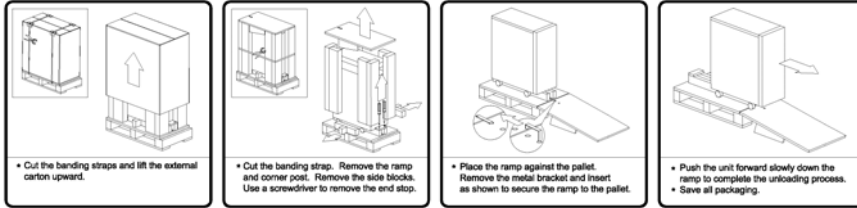

WARNING: Qualified Service Personnel **ONLY** must perform the Installation and Servicing of these Battery Packs. MINUTEMAN accepts no liabilities and is not limited to: injury to the Service Personnel, or damages to; the Battery Pack, the UPS, or the connected equipment caused by the incorrect installation or servicing of the Battery Packs. These Battery Packs **MUST** be operated with their respective UPS models, see the table below:

Endeavor Series

Model #	EDBP1000T
UPS Model #	ED1000T ED10200T ED6000T ED6200T



NOTICE: This equipment has been tested and found to comply with the limits for a Class A computing device in accordance with the specifications in Subpart J of Part 15 of FCC Rules and the Class A limits for radio noise emissions from digital apparatus set out in the Radio Interference of the Canadian Department of Communications. These limits are designed to provide reasonable protection against such interference in a residential installation. This equipment generates and uses radio frequency and if not installed and used properly, that is, in strict accordance with the manufacturer's instructions, this equipment may cause interference to radio and television reception. If this equipment does cause interference to radio or television reception, which can be determined by turning the equipment off and on, the user is encouraged to try to correct the interference by one or more of the following measures:

- Re-orient the receiving antenna.
- Relocate the computer with respect to the receiver.
- Move the computer away from the receiver.
- Plug the computer into a different outlet so that the computer and receiver are on different branch circuits.
- Shielded communications interface cables must be used with this product.



WARNING: Changes or modifications to this unit not expressly approved by the party responsible for compliance could void the user's authority to operate the equipment.

Life Support Policy

As a general policy, we do not recommend the use of any of our products in life support applications where failure or malfunction of the product can be reasonably expected to cause failure of the life support device or to significantly affect its safety or effectiveness. We do not recommend the use of any of our products in direct patient care. We will not knowingly sell our products for use in such applications unless it receives in writing assurances satisfactory to us that (a) the risks of injury or damage have been minimized, (b) the customer assumes all such risks, and (c) our liability is adequately protected under the circumstances.

Examples of devices considered to be life support devices are neonatal oxygen analyzers, nerve stimulators (whether used for anesthesia, pain relief, or other purposes), auto transfusion devices, blood pumps, defibrillators, arrhythmia detectors and alarms, pacemakers, hemodialysis systems, peritoneal dialysis systems, neonatal ventilator incubators, ventilators for both adults and infants, anesthesia ventilators, and infusion pumps as well as any other devices designated as "critical" by the United States FDA.

2. CONTROLS

REAR PANEL

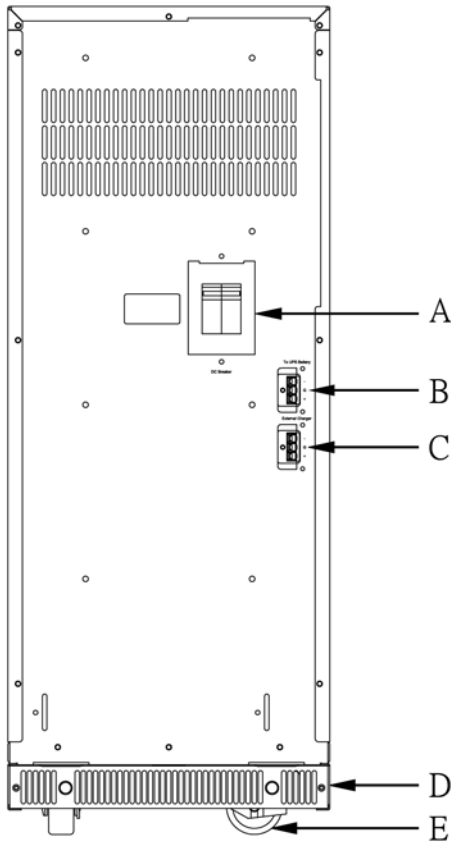

- A. The DC Circuit Breaker connects and disconnects the DC bus voltage from the Battery Pack to the UPS. The DC Circuit Breaker will trip in the event of a DC over-current condition.
- B. The Battery connector is for connecting an External Battery Pack.
- C. The Battery connector is for Daisy Chaining an additional External Battery Pack or connecting an External Charger.
- D. Caster cover plate.
- E. Casters.

3. INSTALLATION

INSTALLATION PLACEMENT

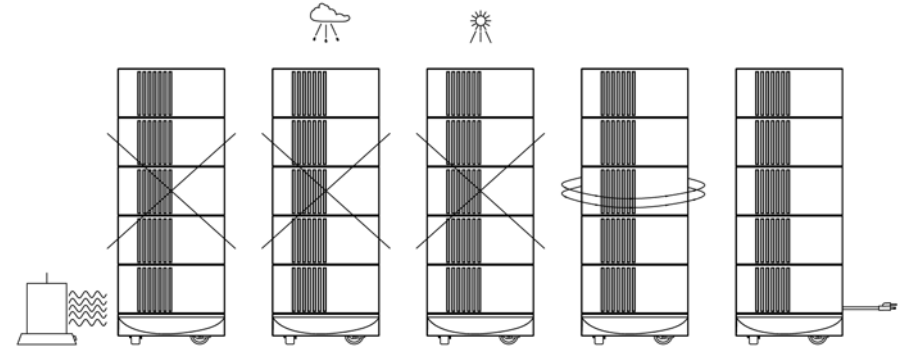

These Battery Packs are intended to be install in a temperature controlled environment that is free of conductive contaminants. Select a location which will provide good air circulation for the Battery Pack at all times. Avoid locations near heating devices, water or excessive humidity, or where the Battery Pack is exposed to direct sunlight. Route power cords so they cannot be walked on or damaged.

ENVIRONMENTAL	
Operating Temperature (max)	0 to 40°C (+32 to +104°F)
Storage Temperature	-15 to +45°C (+5 to +113°F)
Operating/Storage Humidity	95% Non-Condensing
Operating Elevation	0 to 3,000m (0 to +10,000 ft)
Storage Elevation	0 to 15,000m (0 to +50,000 ft)

INSTALLATION

Be sure to read the installation placement and all the cautions before installing the Battery Pack. Place the Battery Pack in the final desired location and complete the rest of the installation procedure.



WARNING! These Battery Packs are extremely heavy. Any time the Battery Pack has to be handled be sure to use, enough personnel, strong supports and equipment to safely handle the Battery Pack.

INSTALLATION OF THE CASTER COVERS (QUALIFIED SERVICE PERSONNEL ONLY)

1. Lock the casters so that the unit will not move.
2. Step 1: There are two A1 cover plates, one for each side of the unit. Insert the A1 cover plates into the slots and slide towards the rear of the unit.
3. Step 2: There are two A2 cover plates, one is for the front of the unit and the other is for the rear of the unit. Insert the A2 cover plates into the slots and push downwards toward the floor.
4. Step 3: There are four retaining screws S1. Install the S1 retaining screws into the A2 cover plates.
5. Step 4: There is one A3 cover plate. Insert the A3 cover plate into the holes on the A2 cover plate on the front of the unit and press firmly.

Step 1

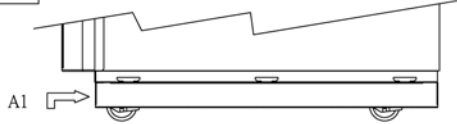

Step 2

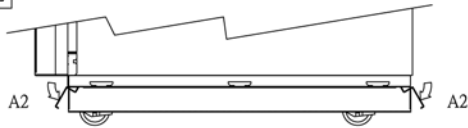

Step 3

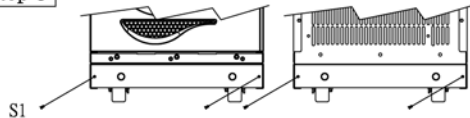

Step 4

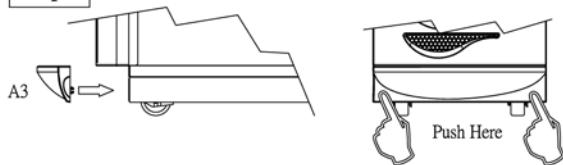

CONNECTING THE BATTERY PACK

(QUALIFIED SERVICE PERSONNEL ONLY)

NOTE: When using these Battery Packs the UPS must be configured so that the UPS will report the correct estimated runtime in the SentryPlus software or the SNMP-NET card. See the SentryPlus software or the SNMP-NET card User's Manual to configure the UPS.

1. Be sure to read the installation placement procedure, all of the cautions and the safety precautions before connecting the Battery Pack(s).
2. Make sure that the DC circuit breaker on the rear panel of the Battery Pack is in the Off position. **CAUTION:** If the Battery Pack's DC circuit breaker is in the On position, the battery voltage will be present at the open end of the Battery Pack's external battery cable and external battery connector.
3. Press the Off button on the front panel of the UPS.
4. Turn off the input circuit breaker on the rear panel of the UPS.
5. Turn off the Utility input circuit breaker at the service panel.
6. Remove the External Battery Connector cover from the UPS's and the Battery Pack's rear panel.
7. Verify, before connecting the Battery Pack's external battery cable into the UPS's external battery connector, that they mate red to red and black to black. **NOTE:** The red connector is the battery positive (+) and the black connector is the battery negative (-). Connect the external battery cable from the Battery Pack to the external battery connector on the UPS. **NOTE:** If connecting more than one Battery Pack see Daisy Chaining.
8. Turn the DC circuit breaker on the rear panel of the Battery Pack to the On position.
9. The Battery Packs are ready for normal operation, see the UPS User's Manual for the normal startup of the UPS.

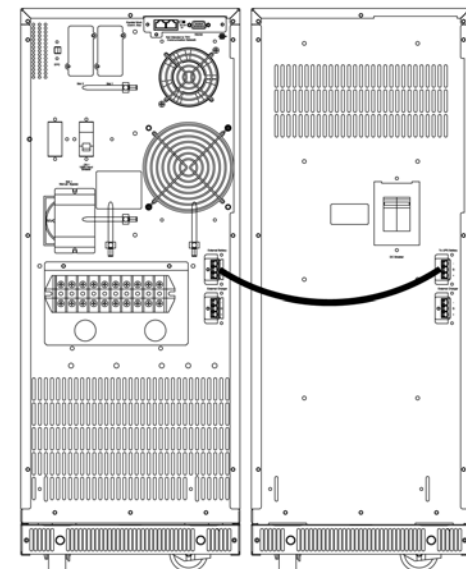

DAISY CHAINING

(QUALIFIED SERVICE PERSONNEL ONLY)

"Daisy Chaining" means hooking one Battery Pack to another Battery Pack to another Battery Pack, this chain could go on indefinitely. Follow the steps below to Daisy Chain the Battery Packs.

1. Be sure to read the installation placement procedure, all of the cautions and the safety precautions before Daisy Chaining the Battery Pack(s).
2. Make sure that the DC circuit breakers on the rear panel of the Battery Packs are in the Off position. **CAUTION:** If the Battery Pack's DC circuit breaker is in the On position, the battery voltage will be present at the open end of the Battery Pack's external battery cable and external battery connector.
3. Press the Off button on the front panel of the UPS.
4. Turn off the input circuit breaker on the rear panel of the UPS.
5. Turn off the Utility input circuit breaker at the service panel.
6. Remove the External Battery Connector cover from the UPS's rear panel and the additional Battery Packs.
7. Verify, before plugging the external battery cable into the UPS's external battery connector or the Battery Pack's external connector that they mate red to red and black to black.
8. Connect the external battery cable from the first Battery Pack to the external battery connector on the UPS.
9. Connect the external battery cable from the second Battery Pack to the external battery connector on the first Battery Pack.
10. Turn ALL of the DC circuit breakers on the rear panel of the Battery Packs to the On position.
11. The Battery Packs are ready for normal operation, see the UPS User's Manual for the normal startup of the UPS.

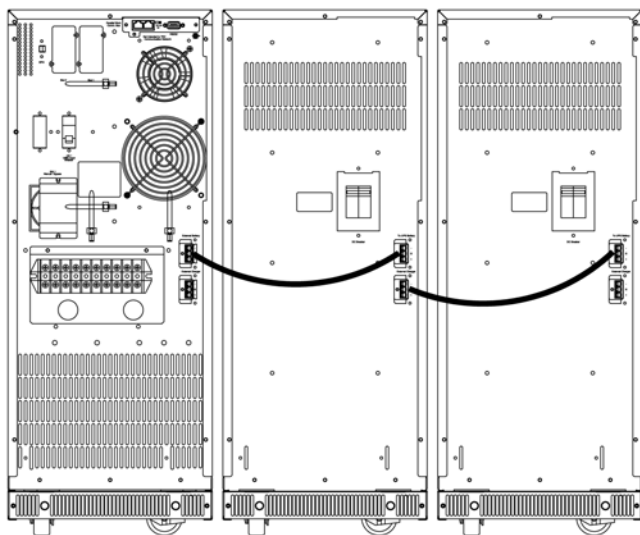

4. REPLACING THE BATTERY

(QUALIFIED SERVICE PERSONNEL ONLY)

Please read all of the **WARNINGS** and **CAUTIONS** before attempting to service the batteries.

WARNING! This Battery Pack contains potentially hazardous voltages. Do not attempt to disassemble the Battery Pack beyond the battery replacement procedure. These Battery Packs contain no user serviceable parts. Repairs and Battery replacement must be performed by **QUALIFIED SERVICE PERSONNEL ONLY**.



CAUTION: Do not open or mutilate batteries. Released electrolyte is harmful to the skin and eyes and may be toxic.

CAUTION: Do not dispose of batteries in a fire. The batteries may explode. The batteries in this Battery Pack are recyclable. Dispose of the batteries properly. The batteries contain lead and pose a hazard to the environment and human health if not disposed of properly. Refer to local codes for proper disposal requirements or return the battery to the supplier.



CAUTION: The battery system voltages are 240VDC. The battery system can still present a risk of electrical shock. These batteries produce sufficient current to burn wire or tools very rapidly, producing molten metal. Observe these precautions when replacing the batteries:



1. Remove watches, rings, or other metal objects.
2. Use hand tools with insulated handles.
3. Wear protective eye gear (goggles), rubber gloves and boots.
4. Do not lay tools or other metal parts on top of batteries.
5. Disconnect the charging source prior to connecting or disconnecting the battery terminals.
6. Determine if the battery is inadvertently grounded. If the battery is, remove the source of the grounding. Contact with any part of a grounded battery can result in an electrical shock. The likelihood of such shock will be reduced, if such grounds are removed during installation and maintenance.

CAUTION: Replace the batteries with the same number and type as originally installed in the Battery Pack. These batteries have pressure operated vents. These Battery Packs contain sealed non-spillable maintenance free lead acid batteries.

Model #	EDBP10000T
Battery Qty/Rating	40 - 12V9.0Ah
Yuasa Part #	NPW45-12
CSB Part #	HR 1234W F2

BATTERY REPLACEMENT PROCEDURE

(QUALIFIED SERVICE PERSONNEL ONLY)

PLEASE READ THE CAUTIONS AND WARNINGS BEFORE ATTEMPTING TO REPLACE THE BATTERIES

1. Turn Off all of the DC circuit breakers on the rear panel of the Battery Packs.
2. Disconnect all of the battery cables from the UPS and the Battery Pack.
3. Remove the retaining screws for the top cover on the rear panel of the Battery Pack.
4. Slide the top cover towards the rear of the Battery Pack and lift up to remove the top cover. Set aside the top cover. (FIG. 1)
5. Remove the retaining screws for the side panels on the rear panel of the Battery Pack.
6. Slide the side panels towards the rear of the Battery Pack and lift up to remove the side panels. Set aside the side panels. (FIG. 2)

FIG. 1

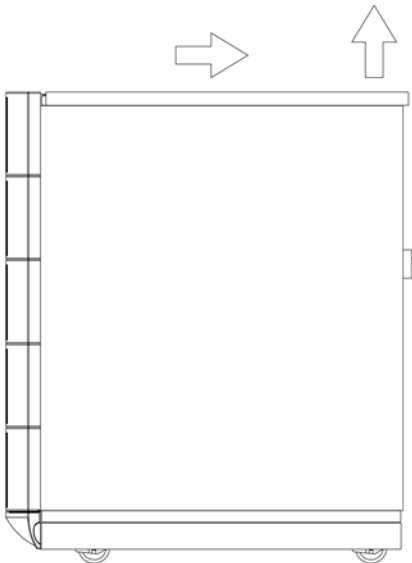
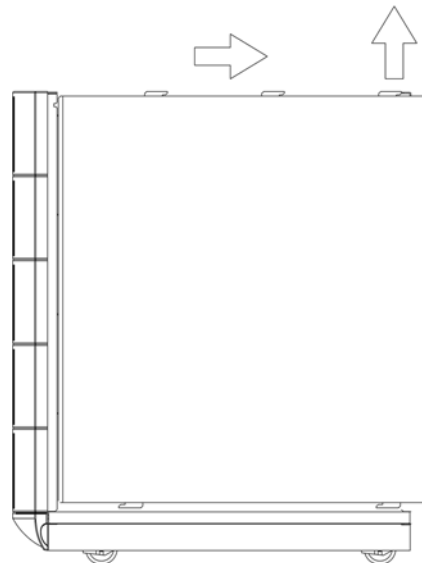
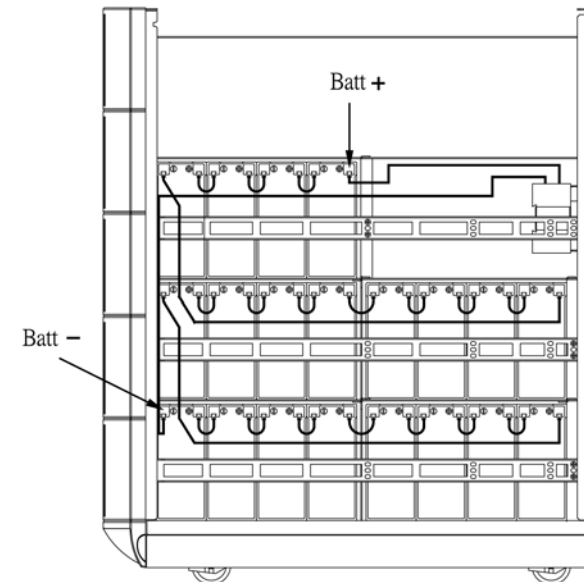

FIG. 2



7. Looking from the front of the Battery Pack on the right-hand side (FIG. 3), disconnect the battery positive (Red) wire. Place a piece of electrical tape over the end of battery positive (Red) wire.
 8. Looking from the front of the Battery Pack on the left-hand side (FIG. 4), disconnect the battery positive (Red) wire. Place a piece of electrical tape over the end of battery positive (Red) wire.
 9. Back to the right-hand side (FIG. 3). Disconnect the battery negative (Black) wire.
 10. Disconnect all of the battery jumper wires.
 11. Remove the battery-retaining bracket retaining screws.
 12. Remove the battery-retaining brackets.
 13. Remove the defective batteries and set aside.
 14. Install the new batteries in the same position as the original batteries.
 15. Re-install the battery-retaining brackets.
- NOTE: DO NOT** pinch the battery wires between the batteries and the battery-retaining brackets.
16. Re-install the battery-retaining bracket retaining screws.
 17. Observe polarity. Reconnect all of the battery jumper wires.
 18. Observe polarity. Reconnect the battery negative (Black) wire.
- NOTE: DO NOT** Reconnect the battery positive (Red) wire at this time.
19. Looking from the front of the Battery Pack on the left-hand side (FIG. 4), disconnect the battery negative (Black) wire.
 20. Disconnect all of the battery jumper wires.
 21. Remove the battery-retaining bracket retaining screws.

FIG. 3



22. Remove the battery-retaining brackets.
 23. Remove the defective batteries and set aside.
 24. Install the new batteries in the same position as the original batteries.
 25. Re-install the battery-retaining brackets.
- NOTE: DO NOT** pinch the battery wires between the batteries and the battery-retaining brackets.
26. Re-install the battery-retaining bracket retaining screws.
 27. Observe polarity. Reconnect all of the battery jumper wires.
 28. Observe polarity. Reconnect the battery negative (Black) wire.
 29. Remove the piece of electrical tape from the end of battery positive (Red) wire. Observe polarity. Reconnect the battery positive (Red) wire.
- NOTE:** Some sparking might occur, this is normal.
30. Back to the right-hand side of the UPS (FIG. 3), remove the piece of electrical tape from the end of battery positive (Red) wire. Observe polarity. Reconnect the battery positive (Red) wire.
 31. Re-install the side panels and the retaining screws.
 32. Re-install the top cover and the retaining screws.
 33. Reconnect the external battery cables.
 34. Turn On all of the DC circuit breakers on the rear panel of the Battery Packs.
 35. The Battery Pack is now ready for the normal operation.
 36. Properly dispose of the old batteries at an appropriate recycling facility or return them to the supplier in the packing material for the new batteries.

FIG. 4

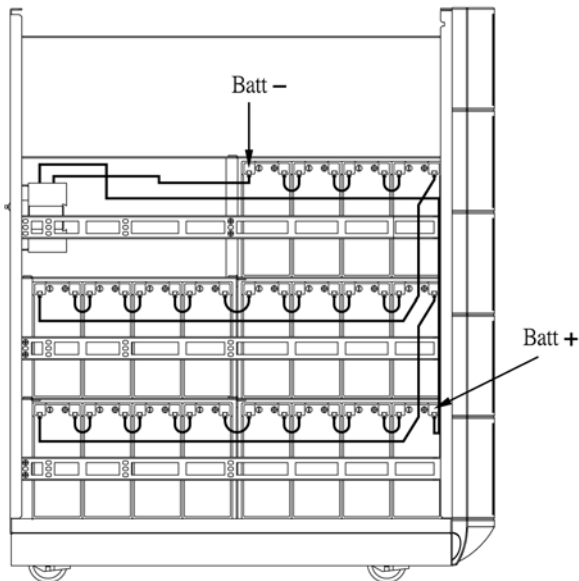

5. OBTAINING SERVICE

IF THE UPS REQUIRES SERVICE

1. Use the **TROUBLESHOOTING** section to eliminate obvious causes.
2. Verify there are no circuit breakers tripped. A tripped circuit breaker is the most common problem.
3. Call your dealer for assistance. If you cannot reach your dealer, or if they cannot resolve the problem call or fax MINUTEMAN Technical Support at the following numbers; Voice phone (972) 446-7363, FAX line (972) 446-9011 or visit our Web site at www.minutemanups.com the "Discussion Board". Please have the following information available BEFORE calling the Technical Support Department.
 - A. Your name and address.
 - B. Where and when the unit was purchased.
 - C. All of the model information about your Battery Pack and UPS.
 - D. Any information on the failure, including LEDs that may be illuminated.
 - E. A description of the protected equipment, including model numbers if possible.
 - F. A technician will ask you for the above information and, if possible, help solve your problem over the phone. In the event that the unit requires factory service, the technician will issue you a Return Material Authorization Number (RMA #).
 - G. If the Battery Pack is under warranty, the repairs will be done at no charge. If not, there will be a charge for repair.
4. Pack the Battery Pack in its original packaging. If the original packaging is no longer available, ask the Technical Support Technician about obtaining a new set. It is important to pack the Battery Pack properly in order to avoid damage in transit. Never use Styrofoam beads for a packing material.
 - A. Include a letter with your name, address, day time phone number, RMA number, a copy of your original sales receipt, and a brief description of the problem.
5. Mark the RMA # on the outside of all packages. The factory cannot accept any package without the RMA # marked on the outside.
6. Return the Battery Pack by insured, prepaid carrier to:

Para Systems Inc.
MINUTEMAN UPS
1455 LeMay Drive
Carrollton, TX 75007
ATTN: RMA # _____

6. SPECIFICATIONS

SYSTEM SPECIFICATIONS

Model Number	EDBP10000T
Format	Rack/Tower Convertible

BATTERY SYSTEM

Battery Type	Sealed, Non-Spillable, Maintenance Free, Value Regulated, Lead Acid
Typical Recharge Time	24-hours from total discharge
Typical Battery Life	3-5 years, depending on discharge cycles and ambient temperature
System Voltage	240VDC
System Current	30 Amps
Battery Qty/Rating	40 - 12V9.0Ah

ENVIRONMENTAL

Operating Temperature	0 to 40°C (+32 to +104°F)
Storage Temperature	-15 to +45°C (+5 to +113°F)
Operating/Storage Humidity	95% Non-Condensing
Operating Elevation	0 to 3,000m (0 to +10,000 ft)
Storage Elevation	0 to 15,000m (0 to +50,000 ft)

PHYSICAL

Size - Net L X W X H	25.4 x 11.4 x 29.4" 645 x 290 x 748 mm
Weight - Net	381 lbs 173 Kgs
Size - Shipping L X W X H	31.9 x 18.4 x 38.5" 810 x 468 x 977 mm
Weight - Shipping	428 lbs 194 Kgs

REGULATORY COMPLIANCE

Safety and Approvals	UL1778, cUL (CSA 22.2 no. 107.1)
EMC Verification	CE certified

7. LIMITED PRODUCT WARRANTY

Para Systems Inc. (Para Systems) warrants this equipment, when properly applied and operated within specified conditions, against faulty materials or workmanship for a period of three years from the date of purchase. For equipment sites within the United States and Canada, this warranty covers repair or replacement of defective equipment at the discretion of Para Systems. Repair will be from the nearest authorized service center. Replacement parts and warranty labor will be borne by Para Systems. For equipment located outside of the United States and Canada, Para Systems only covers faulty parts. Para Systems products repaired or replaced pursuant to this warranty shall be warranted for the unexpired portion of the warranty applying to the original product. This warranty applies only to the original purchaser who must have properly registered the product within 10 days of purchase.

The warranty shall be void if (a) the equipment is damaged by the customer, is improperly used, is subjected to an adverse operating environment, or is operated outside the limits of its electrical specifications; (b) the equipment is repaired or modified by anyone other than Para Systems or Para Systems approved personnel; or (c) has been used in a manner contrary to the product's User's Manual or other written instructions.

Any technical advice furnished before or after delivery in regard to use or application of Para Systems's equipment is furnished without charge and on the basis that it represents Para Systems's best judgment under the circumstances, but it is used at the recipient's sole risk.

EXCEPT AS PROVIDED HEREIN, PARA SYSTEMS MAKES NO WARRANTIES, EXPRESSED OR IMPLIED, INCLUDING WARRANTIES OF MERCHANTABILITY AND FITNESS FOR A PARTICULAR PURPOSE. Some states do not permit limitation of implied warranties; therefore, the aforesaid limitation(s) may not apply to the purchaser.

EXCEPT AS PROVIDED ABOVE, IN NO EVENT WILL PARA SYSTEMS BE LIABLE FOR DIRECT, INDIRECT, SPECIAL, INCIDENTAL, OR CONSEQUENTIAL DAMAGES ARISING OUT OF THE USE OF THIS PRODUCT, EVEN IF ADVISED OF THE POSSIBILITY OF SUCH DAMAGE. Specifically, Para Systems is not liable for any costs, such as lost profits or revenue, loss of equipment, loss of use of equipment, loss of software, loss of data, cost of substitutes, claims by third parties, or otherwise. The sole and exclusive remedy for breach of any warranty, expressed or implied, concerning Para Systems's products and the only obligation of Para Systems hereunder, shall be the repair or replacement of defective equipment, components, or parts; or, at Para Systems's option, refund of the purchase price or substitution with an equivalent replacement product. This warranty gives you specific legal rights and you may also have other rights which vary from state to state.

Longer term warranties are available at an additional cost. Contact Para Systems (1-972-446-7363) for details.

NOTES:

English