



SNMP-NET Client

Shutdown Management Software for Windows 2000/XP/2003

User's Manual

Introduction

SNMP-NET Client is designed to provide the user the ability to take proactive steps to protect their equipment from power related damages. The SNMP-NET Client allows for automatic shutdowns, scheduled shutdowns and a variety of other features that help you manage your system and its peripheral components.

SNMP-NET Client provides detailed information about the UPS and its protected equipment. It is easy to install and program, yet has the necessary features to handle all of one's power requirements.

SNMP-NET Client runs in the background as a Windows service, and communicates with the UPS through SNMP in order to ensure that your computer and attached components are protected from any power problems.

SNMP-NET Client features:

1. Graceful operating system shutdown
2. Scheduled tests, shutdown/restarts of the UPS
3. Notification: e-mail, audible alarm, network broadcasting and SMS
4. Real-time values of voltage, current, frequency and loading
5. Historical data & graph
6. Network monitoring
7. Multi-computer shutdown/restart
8. Support Simple Network Management Protocol (SNMP)

SNMP-NET Client Installation

SNMP-NET Client Setup:

1. Place the SNMP-NET CD in your CD-ROM device and execute the SNMP-NET Client Setup.exe to run the setup program.
2. Check the SNMP configuration of your UPS.
3. After finishing the installation, the setup process will create an SNMP-NET Client association.

Help: SNMP-NET Client on-line help.

Setup: To modify, repair or remove SNMP-NET Client from your hard disk.

SNMP-NET Monitor: A user-friendly interface, that users can review event logs and monitor your UPS.

SNMP-NET Service: SNMP-NET service program is used to communicate with your UPS.

4. Now the SNMP-NET Service should be running in your system, move your mouse over the system tray and click on the right button to pop up a menu. Select Property item and fill in the "IP or Host" file for the SNMP card and assign the community string. This community string should be the same as it is in the SNMP card.

Configure SNMP-NET SNMP Card:

Before configuring the SNMP device you will need to have an administrator account and password. Open the SNMP Access Control page and add your IP address and community string. Please note that the community string must be equal to the SNMP-NET Client's. If you would like to turn off the UPS after the OS shutdown then select the read/write access level, otherwise, select the read only access level. An ideal plan for multiple server shutdowns is to select one or two servers, which have the read/write access level, which should be the last shutdown server(s) and assign, read only access level for the others.

Configuration:

There are 3 servers, which are powered by the UPS and all of them retrieve the UPS information through SNMP-NET SNMP card. In this case only one server is assigned the read/write permission to shutdown the UPS, the others are assigned read only access level to shutdown the operating systems.

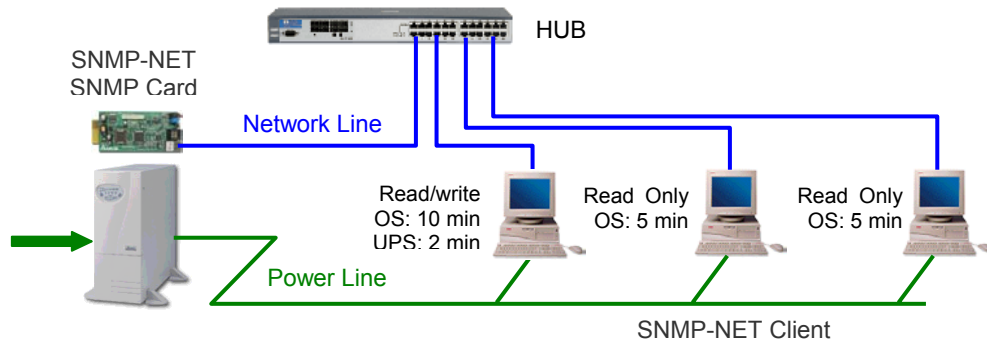

Power Fail:

Once power fail occurs, all of the servers begin to countdown for the graceful shutdown.

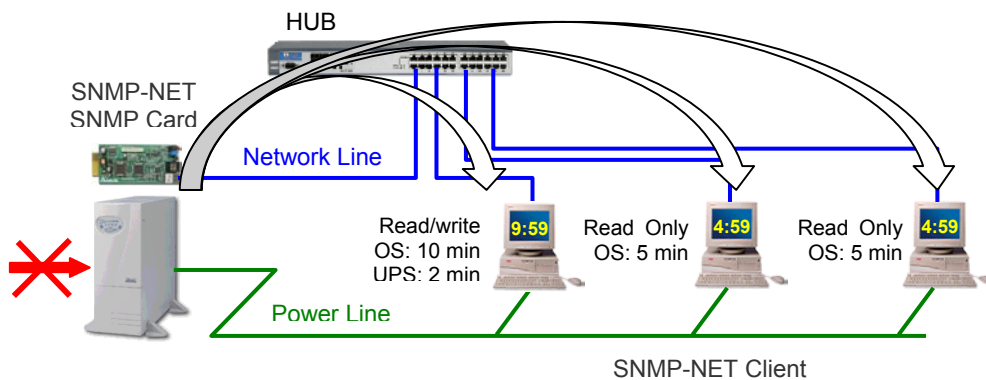

Power Fail Last 5 Minutes:

When the countdown timer reaches 0, SNMP-NET Client shuts down the operating system normally.

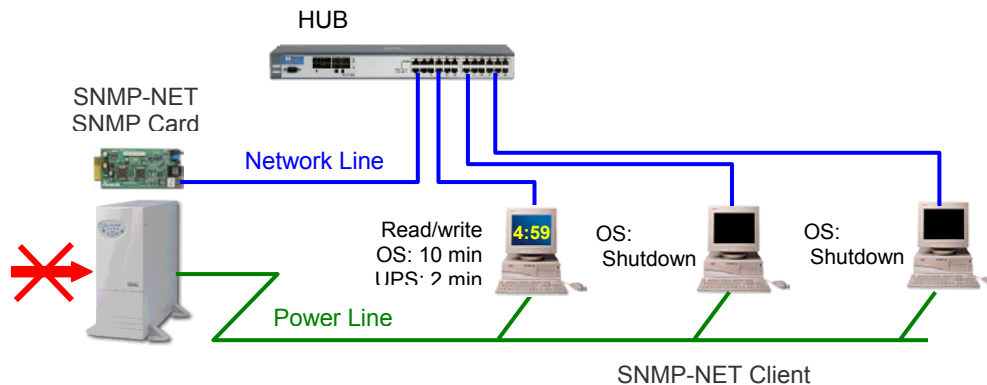

Power Fail Last 10 Minutes:

Before the read/write permission server shuts down, SNMP-NET Client will send a delay shutdown UPS command to the SNMP-NET SNMP card then it will shutdown the operating system.

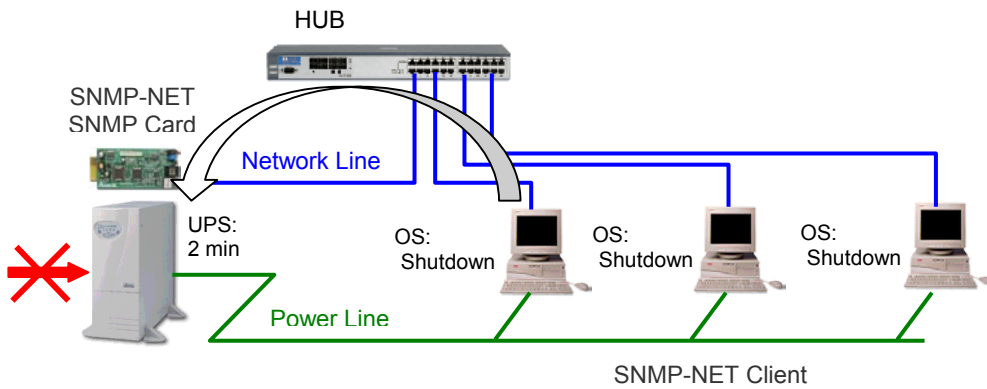

Power Fail Last 12 Minutes:

UPS shuts down to prevent over discharge.

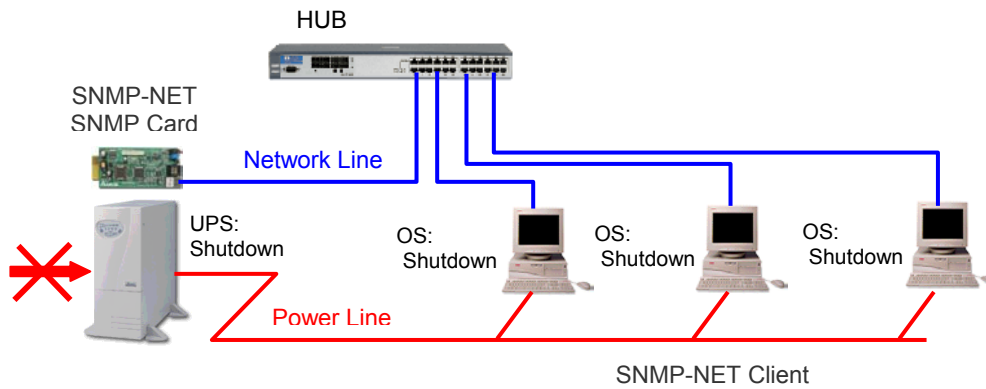

SNMP-NET Service

SNMP-NET Service runs in the background as a Windows Service when the system initiates. You can also run SNMP-NET Service manually by selecting the Start Menu- Program Files - SNMP-NET Client - SNMP-NET Service. Once the SNMP-NET Service starts there will be an SNMP-NET Service icon located in the system tray to indicate UPS status.

Moving your mouse over the SNMP-NET Service icon in the system tray and click the right button to pop up the menu.

- Console Monitor: Run the SNMP-NET Monitor, the user interface.
- Service Panel: Pop up the SNMP-NET Service panel, a brief panel for current UPS status.
- Property: Displays the property window, which allows you to change the SNMP-NET Client parameters.
- Show Panel: Shows SNMP-NET Service panel when the system initiates.
- Topmost Panel: Always keep on the top most windows.
- Stop SNMP-NET Service: If this item is marked SNMP-NET Client Service is stopped. Unmark it and the program will resume.

SNMP-NET Monitor

SNMP-NET Monitor enables you to monitor the UPS through the Main Screen. It is not necessary for SNMP-NET Monitor to reside in your computer's memory the execution depends on the user's requirement. This can save precious system resources.

After finishing the SNMP-NET Client installation, SNMP-NET Service automatically loads into memory and runs once the Windows operating system starts up. There is an SNMP-NET Service icon that is in the system tray to indicate current UPS status.

To run the SNMP-NET Monitor, double click on the Service icon or click the right button to pop up the menu then select Console Monitor to run the program. You can also launch SNMP-NET Monitor by select SNMP-NET Monitor from Program Files – SNMP-NET Client menu.

SNMP-NET Service - Property

General:

Displays the SNMP-NET Client version and UPS rating values here.

IP or Host: This field needs to be assigned a correct IP address or host name of the SNMP-NET SNMP card.

Community: The community is part of an identification of SNMP protocol. Please make sure it is the same as it is in the SNMP-NET SNMP card "SNMP Access Control" page.

Time Server: Enable this option to run a network time service to provide time and date to the SNMP-NET SNMP card; meanwhile, the SNMP-NET SNMP card needs to be assign the host IP address in the Time Server page.

Cancel Shutdown: This button is used to cancel current countdown timer.

Pause Reaction: This button is used to pause current reactions but if another power event occurs the reactions will be resumed.

Run Time:

Users can plan the unattended shutdown timer here, if you would like to shutdown UPS after the OS shutdown you need to get a read/write access level from SNMP-NET SNMP card. To do that, please refer to the **SNMP-NET Client Installation** chapter.

Reaction:

There are 5 reactions for power events, including audible alarm, network broadcast, e-mail, SMS and customer command.

Please make sure the Messenger service is running if you want to broadcast message in the network.

To send a short message to a mobile phone, you need to prepare a GSM modem or mobile phone and connect it to the computer. The SNMP-NET Client communicates with this local mobile phone through enhanced AT commands to send power message to another mobile phone.

Schedule:

The SNMP-NET Client supports two kinds of shutdown schedules – (1) Weekly Schedule, (2) Special Day Schedule. Set both of these options to plan your system schedule shutdown and restart time.